

# 12V 300Ah LiFePO4 Lithium Battery

Over 5000 Cycles Life

Model NO: BG-12300



RV



Camper



Marine



Solar Home



UPS Backup



## Introduction

BG-12300 LiFePO4 Lithium Deep Cycle Battery, is With the Grade A Cells and Built-in Smart BMS, The Designed Life is Up to 10 Years. 5000 Cycles @ 80%DOD. Protections Include: Charging and Discharge Protection, Hardware Protection for Over-Voltage, Under-Voltage, Temperature, Overload, Short Circuit etc. It is Widely Used in Various Applications, Such as RV, Van, Camper, Marine, Camping, Off-Grid, Solar Home, Ups Backup, Golf Cart etc.

## Features

CE

MSDS

UN38.3

Grade A Cells and Built-In Smart BMS

Over Current, Short Circuit, Over Charge and Over Discharge Protection

Black ABS Case and IP65 Waterproof

5000 Cycle Life and 5 Years Warranty

High & Low Temperature Auto Cut-Off Protection

Certified with CE / UN38.3 / MSDS

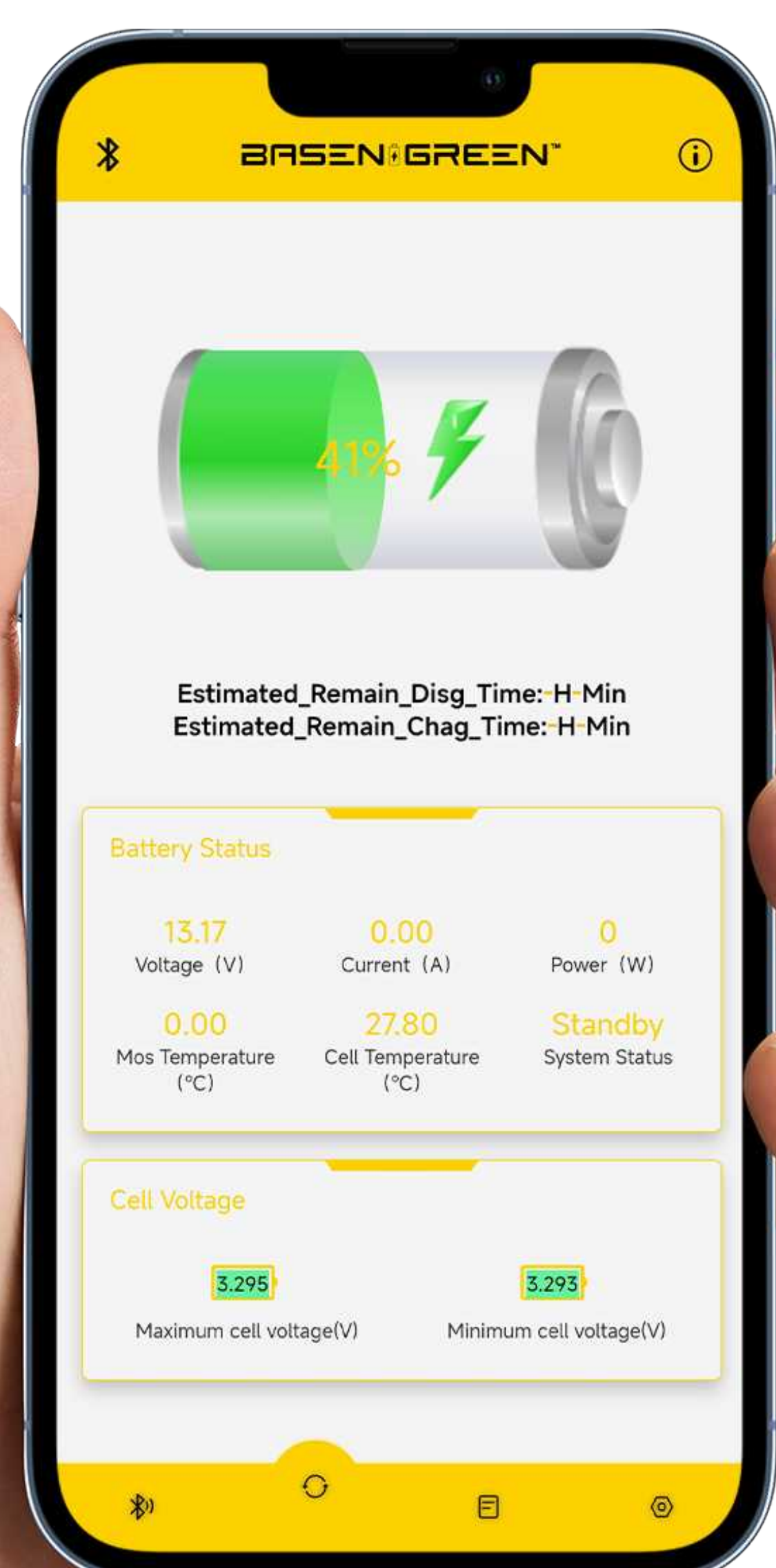

### Bluetooth-APP

SOC Monitor

Temperature Monitor

Voltage Monitor

Current Monitor

Cycle Monitor

Cell Monitor

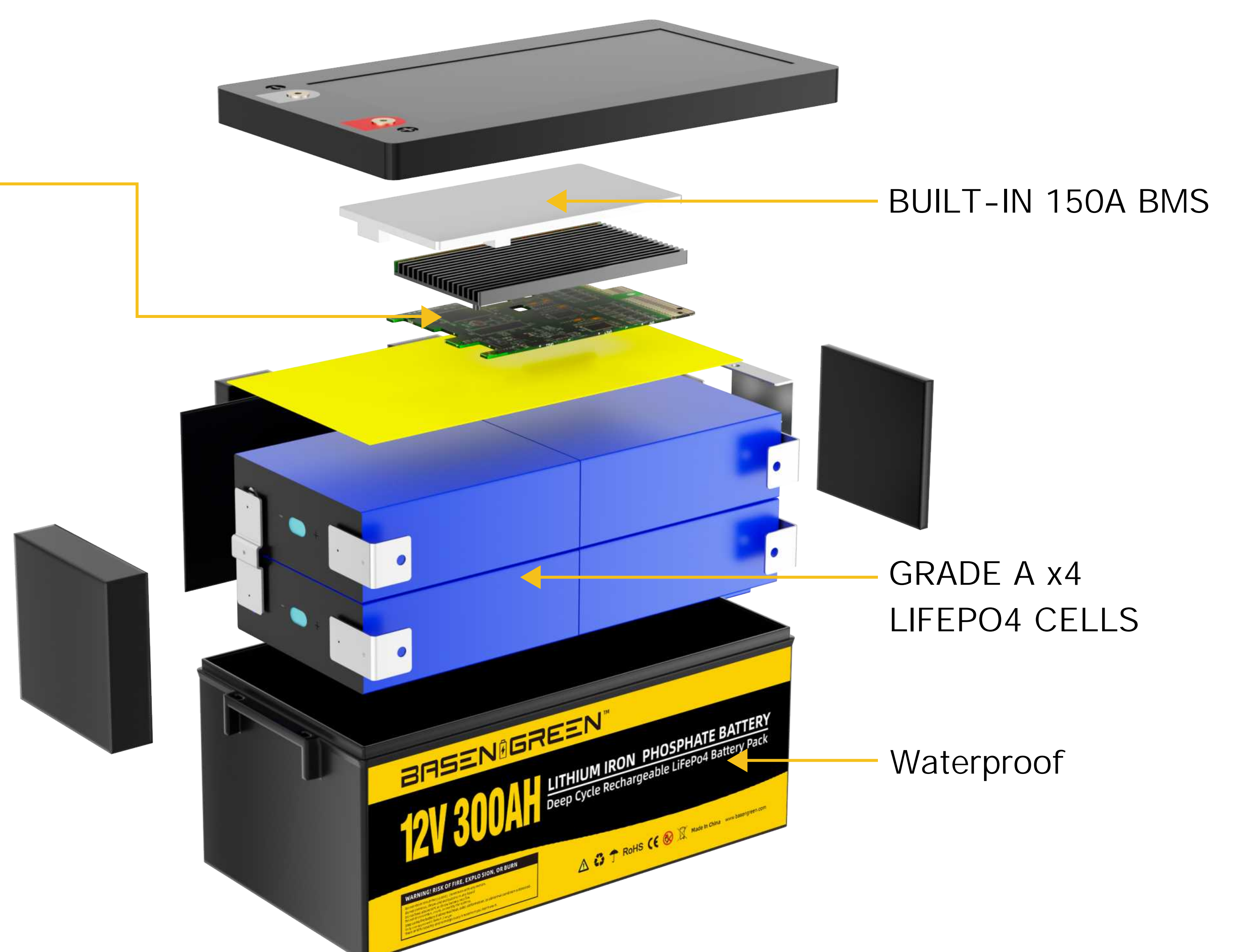



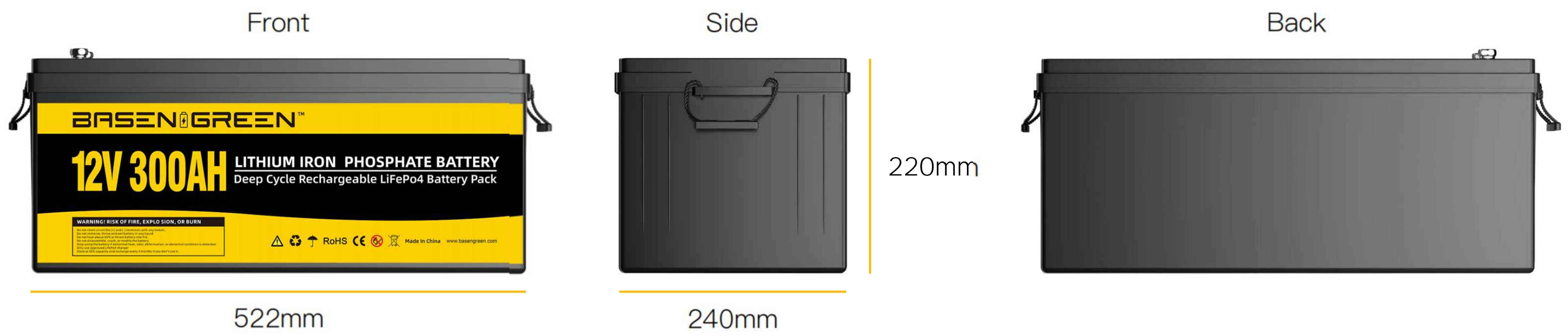

ELECTRICAL PROPERTIES	
Nominal Voltage	12.8V
Nominal Capacity	300Ah
Energy	3840Wh
Self Discharge	< 3% / Month
CHARGE PERFORMANCE	
Maximum Charge Current	150A
Recommend Charge Voltage	14.6V
BMS Charge Cut-off Voltage	14.6V
BMS Charge Cut off Recover	14±0.05V
Balancing Voltage	< 13.2V(3.3V/Cell)
DISCHARGE PERFORMANCE	
Max Continuous Discharge Current	150A
Short Circuit Protection Current	1800±360A
Dischage Cut-off	10.8V
BMS Low-Voltage Protection	10.8±0.05V
BMS Low Voltage Recover	11.6±0.05V
BMS Short Circuit Protection	250µs
TEMPERATURE PERFORMANCE	
Discharge Temperature	-20 ~ 60 °C
Charge Temperature	0 ~ 55 °C
Storage Temperature	10 ~ 35 °C
BMS High Temperature Cut	55±2 °C
BMS High Temperature Recovery	50±2 °C
PHYSICAL PROPERTIES	
Overall Dimensions (LxWxH)	522x240x220mm
Weight	30kg
Terminal Thread Type	M8
Case Material	ABS
Protection Class	IP65
COMPLIANCE	
Certifications	CE,MSDS,UN38.3

