Stackable Battery Pack

Pack Installation & Operation Manual

- BR-BOX-LV 5KWH
- BR-BOX-LV 10KWH
- BR-BOX-LV 20KWH
- BR-BOX-LV 30KWH



Content

| | |
|--|----|
| 1. Preface | 01 |
| 2. Label Explanation | 02 |
| 3. Product Description | 02 |
| 4. Product Advantages | 03 |
| 5. Product Technical Parameters | 03 |
| • 5.1 Product Appearance | 04 |
| • 5.2 Specification | 04 |
| • 5.3 Interface Overview | 05 |
| • 5.4 Battery Management System | 06 |
| • 5.4.1 Overcharge Protection | 06 |
| • 5.4.2 Overdischarge Protection | 06 |
| • 5.4.3 Overcurrent Protection | 06 |
| • 5.4.4 Over Temperature Protection | 06 |
| • 5.4.5 Low Temperature Protection | 06 |
| 6. Installation and Configuration | 07 |
| • 6.1 Packing | 07 |
| • 6.2 Recommended Tools | 08 |
| • 6.3 Notice for Installation | 08 |
| 7. Connection | 10 |
| • 7.1 Precautions Before Connecting The Inverter | 10 |
| • 7.2 Pin definition | 11 |
| • 7.3 Dip Code Switch Definition and Setting | 12 |
| 8. Operation | 13 |
| • 8.1 Check Before Power on | 13 |
| • 8.2 Power on | 13 |
| 9. Operation of Upper System | 14 |
| • 9.1 Log in | 15 |
| • 9.2 Operation of The Communication Protocol Switch | 16 |
| • 9.3 Communication Compatible List | 17 |
| 10. Storage | 18 |
| 11. Warning | 18 |

1. Preface

This manual will provide detailed product information and installation instructions for users of the wall-mounted series products of SHENZHEN BASENGREEN TECHNOLOGY CO.LTD (hereinafter referred to as BASENGREEN). Please read this manual carefully, and put this manual in a place where you can install, operate, and obtain it conveniently.

The safety precautions mentioned in the manual do not represent all the safety matters that should be observed, but are only supplementary to the safety precautions. When installing, operating, and maintaining equipment, local safety regulations and norms should be followed. Only trained professionals can install, operate and maintain equipment. Our company does not assume any responsibility for losses caused by violation of general safety operation requirements or violation of safety standards for the design, production, and use of equipment. Installation and maintenance personnel must have high-voltage and AC power operation skills. When installing, operating, and maintaining equipment, they must not wear any conductive objects, such as watches, bracelets, bracelets, and rings, and prevent moisture from entering the equipment.



Safety Instructions

High Voltage Danger

The high-voltage power supply provides power for the operation of the equipment. Direct contact or indirect contact with high-voltage power supply through wet objects will cause fatal danger.

Use Professional Tools

Always use professional tools instead of personal tools when working with high voltage and AC power

Anti-static

The static electricity generated by the human body will damage the electrostatic sensitive components on the board. Before touching the plug-in, circuit board or chip, make sure to take proper anti-static measures.

Operate Attention

The power must be cut off first before operation, do not hot-line work.

DC short circuit Danger

The power system provides a DC-regulated power supply, and a DC short circuit will damage the equipment and cause personal injury.

2. Label Explanation

The label contains the following information



Guangdong Basengreen New Energy Co.,Ltd

| | |
|---------------------------------|------------------------------|
| Product Name | Rechargeable LiFePO4 Battery |
| Product Model | BR-BOX-LV 5KWH |
| Battery Voltage Operation Range | 43.2Vdc-58.4Vdc |
| Maximum Charge Current | 100A |
| Maximum Discharge Current | 100A |
| Rated Capacity | 100Ah/51.2V/5120Wh |
| Ingress Protection | IP55 |
| Protective Class | 1 |

SN: CE UN38.3 IEC62619













DANGER

DANGER LOW DC VOLTAGE INSIDE
DANGER ARC FLASH & SHOCK HAZARD







- Do not disconnect or disassemble by non-professional personnel.
- Do not drop, deform, hit or pierce with sharp objects.
- Do not place at a children or pet touchable area.
- Do not place near open flame or flammable material.
- Do not cover or wrap the product case.
- Do not sit or put any object on battery.
- Avoid direct sunlight.
- Avoid moisture or liquid.
- The product ingress Protection (IP) class is IP55.
- Make sure the grounding connection is correct before operation.
- Follow the product manual to make wiring connection.
- If leaking, fire, wet or damaged, switch off the breaker on DC side and stay away from battery. Do not touch the leaking liquid.
- Contact your supplier within 24 hours if any failure happens.

3. Product Description

This product is a lithium iron phosphate battery (LFP LiFePO4) composed of 16 cells in series. Which is suitable for home energy storage systems. It can be customized according to customer needs to meet diverse application scenarios and provide stable power for various equipment of users.

4. Product Advantages

- a. Built-in Battery Management System (BMS): Overcharge, overdischarge, overcurrent, temperature control, short circuit and other protection functions.
- b. Passive Balance Function: There is a voltage equalization function during the charging.
- c. High Cost Performance: High safety performance, long service life, stable and reliable quality.
- d. Expandable: Equipped with RS232/ RS485/ CAN bus ports, support up to 15 units in parallel.
- e. Wide Working Temperature: -20°C to 60°C , excellent high-temperature discharge performance.
- f. Convenient: Modular design, small size and lightweight, easy to install and maintain.

5. Product Technical Parameters

5.1 Product Appearance

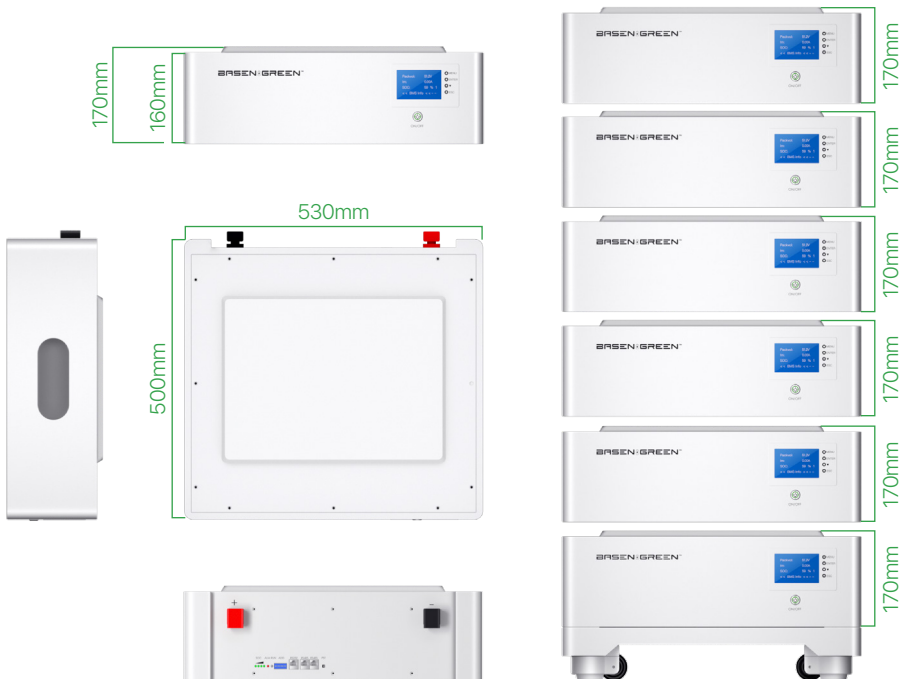

5.2 Specifications

| Item | Specifications | | | |
|----------------------------------|----------------|-----------------|-----------------|-----------------|
| Model | BR-BOX-LV 5KWH | BR-BOX-LV 10KWH | BR-BOX-LV 20KWH | BR-BOX-LV 30KWH |
| Nominal Voltage | 51.2V | 51.2V | 51.2V | 51.2V |
| Operating Voltage | 43.2V-57.6V | 43.2V-57.6V | 43.2V-57.6V | 43.2V-57.6V |
| Nominal Capacity | 100Ah | 200Ah | 400Ah | 600Ah |
| Total Energy | 5120Wh | 10240Wh | 20480Wh | 30720Wh |
| Configuration | 1P16S | (1P16S)*2 | (1P16S)*4 | (1P16S)*6 |
| Charging Cut-off Voltage | 58.4V | 58.4V | 58.4V | 58.4V |
| Discharge Cut-off Voltage | 43.2V | 43.2V | 43.2V | 43.2V |
| Operation Temperature | -20℃~60℃ | -20℃~60℃ | -20℃~60℃ | -20℃~60℃ |
| Standard Charging Current | 20A | 40A | 80A | 100A |
| Max Continuous Charging Current | 100A | 100A | 100A | 100A |
| Max Continuous Discharge Current | 100A | 100A | 100A | 100A |
| Dimension | 615*532*187mm | 530*500*425mm | 530*500*745mm | 530*500*1065mm |
| Net weight | 56KG | 104KG | 200KG | 295KG |

5.3 Interface Overview

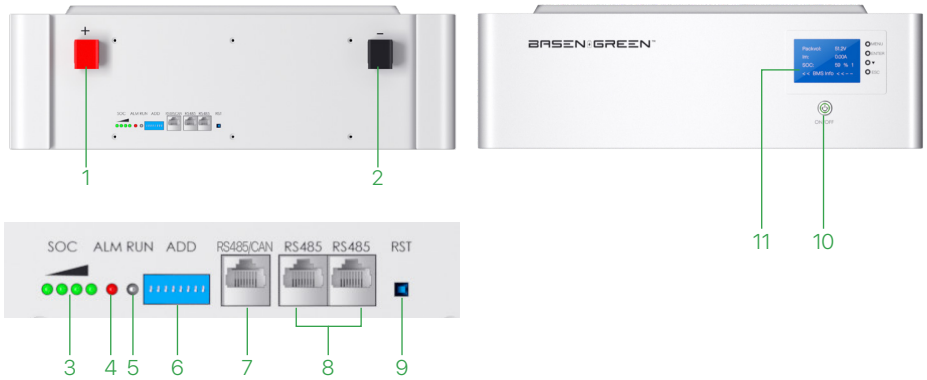

| Position | Item | Description |
|----------|--------------|---|
| 1 | P+ | The positive terminal of the battery, can be connected to the positive pole of the inverter through a cable for DC output |
| 2 | P- | The negative terminal of the battery, can be connected to the negative pole of the inverter through a cable for DC output |
| 3 | SOC | 4 indicators, indicating the remaining power status |
| 4 | Alarm | Indicating the abnormal state of the battery, if there is an low voltage or over voltage, the alarm will sound |
| 5 | RUN | Indicating the normal operation status of the battery |
| 6 | ADD | Setting up battery parallel communication and inverter communication |
| 7 | RS485/CAN | RS485/CAN port for the inverter or the upper system communication |
| 8 | RS485 B/C | RS485 port for parallel communication |
| 9 | RST | Manual-return switch button |
| 10 | Power switch | The switch for turn on/turn off the battery pack |
| 11 | LCD Screen | Display battery voltage, SOC, temperature, etc |

5.4 Battery Management System (BMS)

5.4.1 Overcharge Protection

When the voltage of any single cell or whole battery pack is higher than the set value during the charging, and the duration reaches the limited time, the system enters the over charging protection state automatically, the charging MOS is turned off at the same time, and the battery cannot be charged. After the voltage of each cell and the whole battery pack drops below the cell over charging recovery value, the over charging protection state is released. It can also be released by discharging to return to normal state.

5.4.2 Overdischarge Protection

When the voltage of any single cell or whole battery pack is lower than the set value during discharging, and the duration reaches the limited time, the system enters the overdischarge protection state, the discharge MOS is turned off, and the battery cannot be discharged. After the overdischarge protection of the battery pack occurs, it can be released by charging the battery pack.

5.4.3 Overcurrent Protection

During charging and discharging, when the current exceeds the set value of the protection current, and the duration reaches the limited time, the system enters the overcurrent protection state, the charging and discharging MOS will be turned off automatically, and the battery cannot be charged and discharged, charging and discharging the battery pack can release the overcurrent protection state.

5.4.4 Over Temperature Protection

When the NTC detects the temperature of the battery cell surface is higher than the setting value of over temperature protection during charging and discharging, the management system enters the over temperature protection state, the charging or discharging MOS is turned off, and the battery pack cannot be charged or discharged in this state.

5.4.5 Low Temperature Protection

When the NTC detects that the temperature of the cell surface is lower than the setting value of low temperature protection during charging and discharging, the management system enters the low temperature protection state, the charging or discharging MOS is turned off, and the battery pack cannot be charged or discharged in this state.

6. Installation and configuration

6.1 Packing

a. After receiving the battery, open the box to check the battery surface if get any broken, crack,s or other bad phenomena; if get that, please do not install, and need to contact the supplier, and wait for the supplier's reply before proceeding to the next step.

b. Please ensure that the following items are included in the packaging:



Battery*1



M6*12mm
combination screws*2



Inverter
communication cable*1



Parallel
communication cable*1



Upper system
communication cable*1

C. The battery base is packed separately, each base is equipped with 4 horizontal adjustable universal wheels, customers can purchase the battery base according to the number of stacked packs, the load capacity of the base is 500KG, **support up to 8 units stacked.**



Support up to 8 units stacked

6.2 Installation Procedure

- Use a multi-meter to measure whether the positive and negative cable wires are conducting, and check whether the positive and negative terminal connections are loose.
- The battery should be switched off before wiring to ensure that there is no DC output from the battery.
- Connect positive terminals of the battery and the inverter with red power cable, and then connect negative terminals of both sides with black power cable.
- Connect both communication ports of the battery(RS485/CAN) and the inverter(BMS port) with the communication cable, BMS ports of inverter have different definition for some brands, pls check inverter manule.

Notice: The standard packing list does not include the parallel cable(positive and negative).

6.3 Installation Diagrams

Positive cable

Communication cable

Negative cable

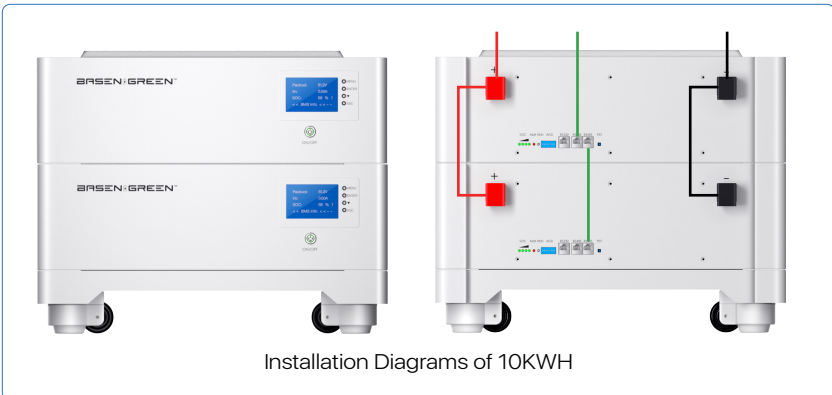
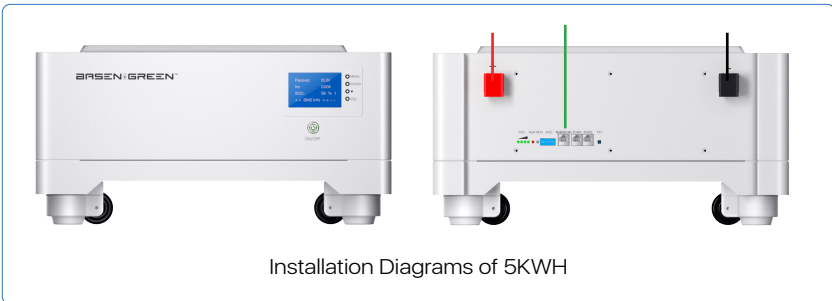

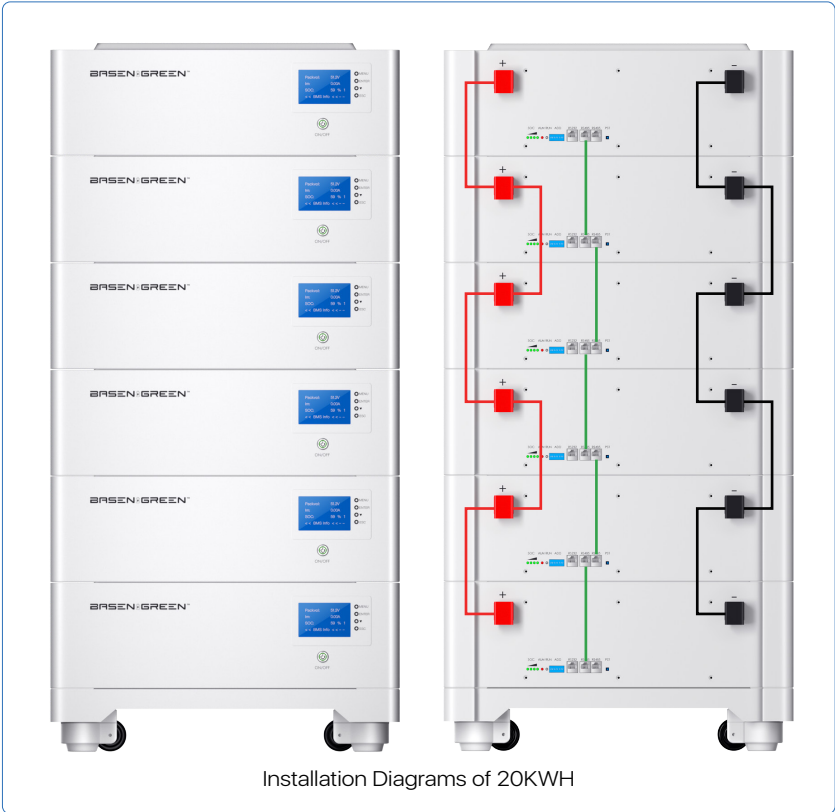
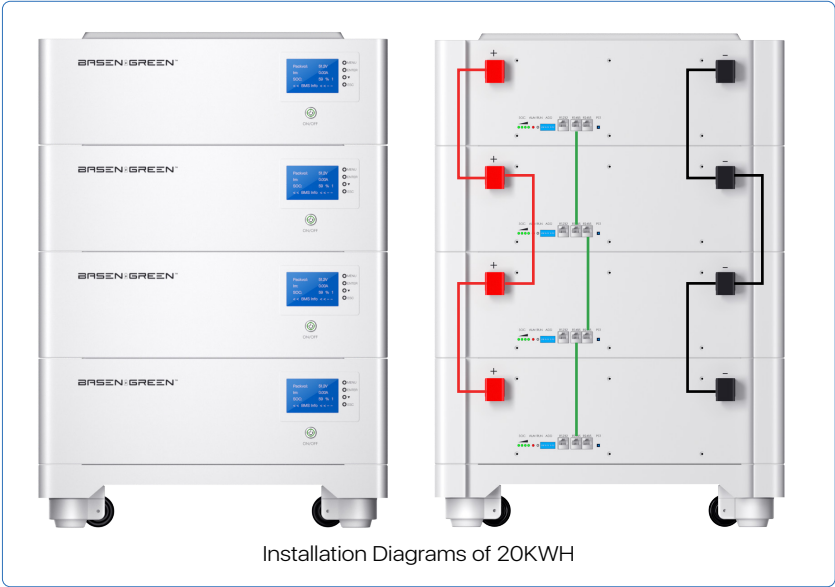

7. Connection

7.1 Precautions Before Connecting The Inverter

- Use a multi-meter to measure whether the positive and negative cable wires are conducting, and check whether the positive and negative terminal connections are loose.
- The battery should be switched off before wiring to ensure that there is no DC output from the battery.
- Connect positive terminals of the battery and the inverter with red power cable, and then connect negative terminals of both sides with black power cable.
- The communication cable connects to the RS485/CAN port on the battery and then to the BMS port on the inverter.

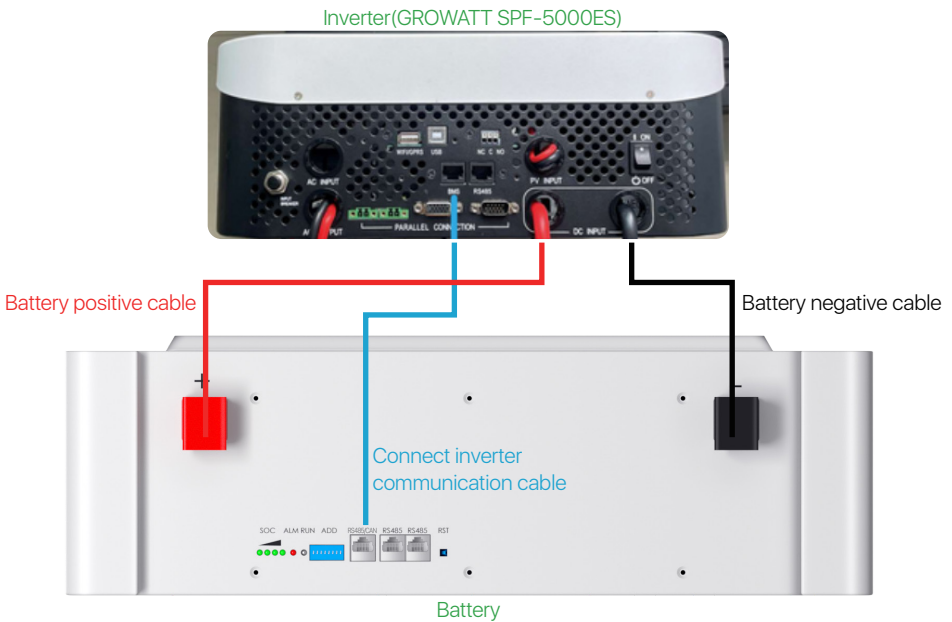

7.2 Pin Definition

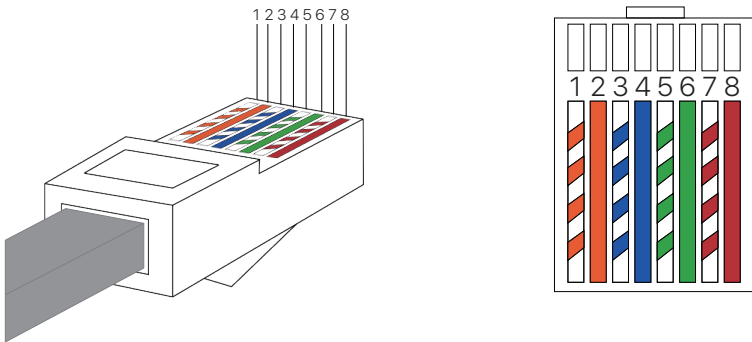
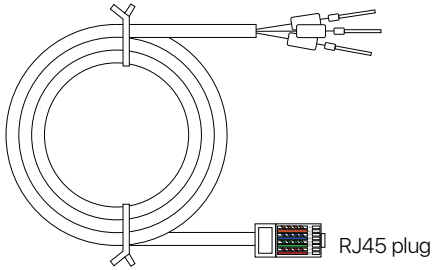

a. RS485/CAN Communication cable connection Pin definition is as follows:

| PIN | 1 | 2 | 3 | 4 | 5 | 6 | 7 | 8 |
|--------|---------|---------|-----|-------|-------|-----|----|----|
| Define | RS485-B | RS485-A | GND | CAN-H | CAN-L | GND | NC | NC |

b. Parallel Communication cable connection Pin definition is as follows:





















| PIN | 1 | 2 | 3 | 4 | 5 | 6 | 7 | 8 |
|--------|---------|---------|-----|----|----|-----|---------|---------|
| Define | RS485-B | RS485-A | GND | NC | NC | GND | RS485-B | RS485-A |

7.3 Dip Code Switch Definition and Setting

ADD switch is an 8-bit DIP switch to manually distribute the communication address of parallel batteries.

The BMS will only recognize the DIP address once it is reset, so please reset the BMS when the DIP address is changed (the BMS must be reset in the standby state). When the DIP address is 0, the battery is configured as the stand-alone working mode; when the DIP address is 1, the BMS is configured as the master working mode; when the DIP address is 2 to 6, the BMS is configured as the slave working mode.

Please refer to the table below to set the DIP switch for parallel connection of different batteries.

| Number | Master1 | Slave 2 | Slave 3 | Slave 4 | Slave 5 | Slave 6 |
|--------|---|---|---|---|---|---|
| 1 |  | | | | | |
| 2 |  |  | | | | |
| 3 |  |  |  | | | |
| 4 |  |  |  |  | | |
| 5 |  |  |  |  |  | |
| 6 |  |  |  |  |  |  |

8. Operation

8.1 Check Before Power on

- a. Check all positive, negative cables and communication lines are connected correctly and safely.
- b. Check the battery is firmly installed, easy to operate and maintain, and check ventilation.
- c. Insulate the unused ports.

8.2 Power on

- a. Turn on the switch on the battery.
- b. The green running LED is normal on(Check the status of the LED indicators)
- c. If it is failed to switch on the battery system, check if all the electrical connection is correct.
- d. If the electrical connection is correct, but the battery system is still unable to switch on, contact our after-sale service within 48 hours

LED Indicator Status

| Status | | Charging | | | | Discharge | | | |
|--------------------------|--------|----------|-------|-------|-------|-----------|-------|-------|-------|
| Capacity Indicator | | L1● | L2● | L3● | L4● | L1● | L2● | L3● | L4● |
| Battery Level | 0~25% | Flash | OFF | OFF | OFF | Light | OFF | OFF | OFF |
| | 25~50% | Light | Flash | OFF | OFF | Light | Light | OFF | OFF |
| | 50~75% | Light | Light | Flash | OFF | Light | Light | Light | OFF |
| | ≥75% | Light | Light | Light | Flash | Light | Light | Light | Light |
| Normal Status Indicator● | | Light | | | | Flash | | | |

Flashing Definition

| Item | Light | OFF |
|---------|--------|--------|
| Flash 1 | 0.25 s | 3.75 s |
| Flash 2 | 0.5 s | 0.5 s |
| Flash 3 | 0.5 s | 1.5 s |

LED Flashing Faulty

| Status | Normal/warning/ protection | RUN | ALM | Battery capacity LED | | | | Specification |
|-----------|--|---------|---------|--|---|---|---|-------------------|
| | | ● | ● | ● | ● | ● | ● | |
| Power off | Sleep | OFF | OFF | ALL OFF | | | | |
| Stand by | Normal | Light | OFF | ALL OFF | | | | |
| Charging | Normal | Light | OFF | Display according to the actual SOC | | | | |
| | Over Current Alarm | Light | Flash 2 | | | | | |
| | Over Voltage Protection | Flash 1 | OFF | ALL OFF | | | | |
| | Over temperature /Over Current Protection | Flash 1 | Flash 1 | ALL OFF | | | | |
| Discharge | Normal | Flash 3 | OFF | Display according to the actual SOC | | | | |
| | Alarm | Flash 3 | Flash 3 | | | | | |
| | Temperature/ Over Current /Short circuit Protection | OFF | Light | ALL OFF | | | | Cut-off Discharge |
| | Low Voltage Protection | OFF | OFF | ALL OFF | | | | Cut-off Discharge |

9. Operation of Upper System

BASEN 48V battery pack supports to connect with our upper system to monitor the status of the battery and modify the communication protocol, please contact our sales representative or visit our website to get the latest upper system software.

9.1 Log in

- a. The upper system communication cable connects to the RS485 port on the battery and then to the USB port on the PC/Laptop
- b. Download and open the upper system software
- c. Modify the language
- d. Updated the status of battery automatically

Notice: If it is failed to connect to the upper system, check if all the connection is correct. If the connection is correct, but the upper system is still unable to work, please contact our after-sale service



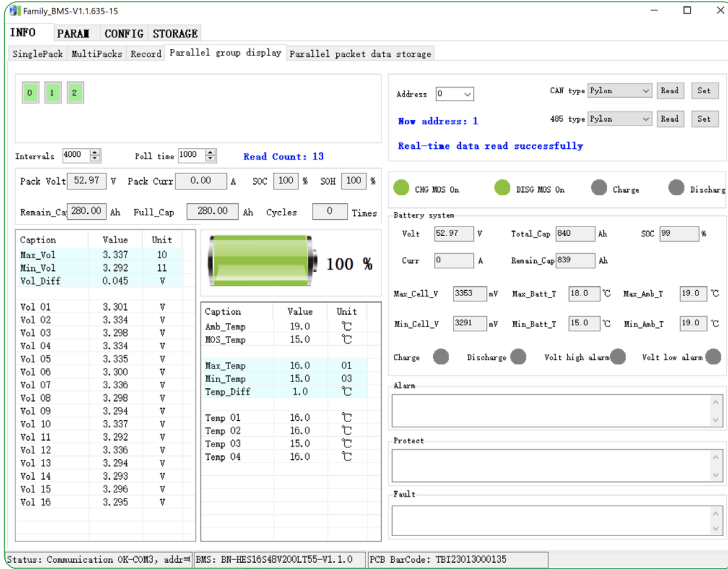

9.2 Operation of The Communication Protocol Switch

Connect to the upper system and follow the path:

INFO—Parallel Group Display—CAN Type/RS485 Type—Read—Choose the protocol—Set

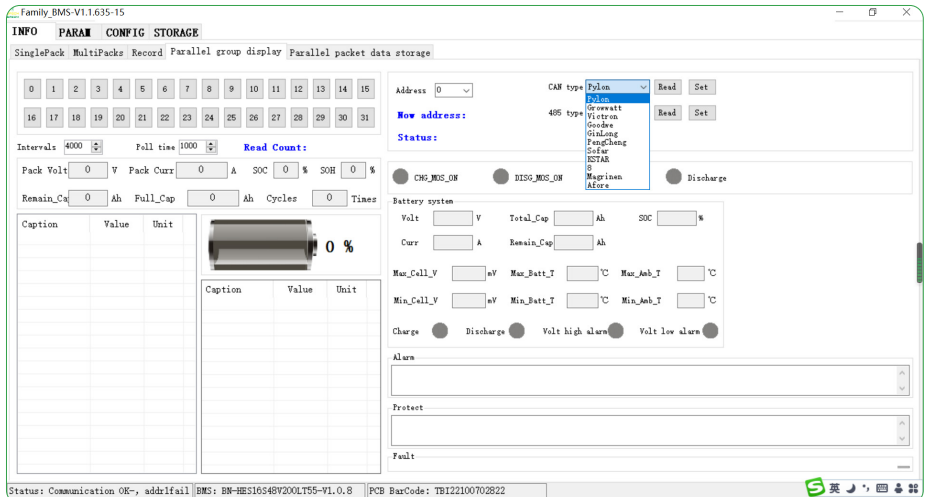

9.3 Communication Compatible List

| Inverter Brand | | Communication method | Protocol Name | Protocol Remarks | Communication波特率 | Interface Definition |
|-------------------------|---|----------------------|--|---------------------------|------------------|----------------------|
| 维克托-Victtron |  | CAN | Victtron-CAN-V1.00- 211135 | Active Upload | 500K | 7H、8L |
| 古瑞瓦特-SPF Growatt-SPF |  | 485 | Growatt BMS-RS485-protocol-1xSxP_ESSL_V2.01 Growatt BMS-RS485-protocol-V2.0 | MODBUS Standard protocols | 9600 | 1B、2A |
| 古瑞瓦特-SPF Growatt-SPF |  | CAN | Growatt BMS CAN-Bus-protocol-low-voltage-V1.05 | Active Upload | 500K | 4H、5L |
| 古瑞瓦特-SPH Growatt-SPF |  | CAN | Growatt BMS communication protocol of growatt low voltage-V1.01 | Active Upload | 500K | 4H、5L |
| 德业 Deye |  | CAN | Deye LV-CAN communication protocol | Active Upload | 500K | 4H、5L |
| 德业 Deye |  | 485 | 485 Modbus Protocol(4)-deye | MODBUS protocols | 9600 | 1B、2A |
| 尚科-Scolar |  | CAN | Growatt BMS CAN-Bus-protocol-low-voltage-V1.05 | Active Upload | 500K | 4H、5L |
| 国德威-Goodwe |  | CAN | Goodwe-CAN-V1.7-220228-SolarinverterFamily-EN | Active Upload | 500K | 4H、5L |
| 日月元-Voltronic Power |  | 485 | Voltronic Power-485-V1.03-200325 | MODBUS protocols | 9600 | 3B、5A |
| 首航-SOFAR |  | CAN | SOFAR-CAN-V1.00-211117-Rev6 | Active Upload | 500K | 1H、2L |
| 锦浪-Solis |  | CAN | Solis-CAN-V1.0-191228-lowVoltage | Active Upload | 500K | 4H、5L |
| 鹏城-Luxpower |  | CAN | Luxpowertek Battery CAN Protocol -2021 | Active Upload | 500K | 4H、3L |
| 派能-Pylontech |  | 485 | Pylon-485-V3.5-161216-low voltage protocol | 1363 | 115200 | 1B、2A |
| 派能-Pylontech |  | 485 | Pylon-485-V3.5-161216-low voltage protocol | 1363 | 9600 | 1B、2A |
| 派能-Pylontech |  | CAN | Pylon-CAN-V1.2- 180408 -lowVoltage | Active Upload | 500K | 4H、5L |
| 硕日-Srne |  | 485 | shuori BMS Modbus Protocol for RS485 V1.3(2020-11-24) | MODBUS | 9600 | 7A、8B |
| 美世乐 Must |  | CAN | PV1800F-CAN communication Protocol1.04.04 | Active Upload | 100K | 6H、5L |
| 艾思玛 SMA |  | CAN | SMA-CAN-V1.0.0-210630-FSS-ConnectingBat-TI-en-20W | Active Upload | 500K | 4H、5L |
| 索瑞德-SOROTEC |  | CAN | CAN Protocol 1.0(SOROTEC Protocol) | MODBUS Standard protocols | 500K | 4H、5L |
| 索瑞德-SOROTEC |  | 485 | Protocol between Sorotec Inverter and Lithium Battery (RS485) | Active Upload | 500K | 1B、2A |
| SOL-ARK |  | CAN | Sol-Ark CAN Bus Protocol V1.2.pdf4-25-22 | Active Upload | 500K | 4H、5L |
| 迈格瑞能 MEGAREVO |  | CAN | Shenzhen MEGAREVO Hybrid Inverter-5K BMS Protocol V1.01 | Active Upload | 500K | 4H、5L |
| MPP Solar |  | 485 | BMS 485 communication protocol 20200325(2) | MODBUS | 9600 | 1B、2A |
| 拓宝-TBB |  | CAN | CAN BUS Protocol of TBB Lithium Battery BMS Platform V 1.1 | Active Upload | 500K | 4H、5L |
| 盛能杰-Senergy |  | CAN | SenergyINV&BMS_CAN_Protocols | Active Upload | | 4H、5L |

10. Storage

- a. External terminals of the battery pack are insulated and protected.
- b. If the battery pack is stored for a long period of time without use, it is recommended that it be charged 30%-60%, and it is prohibited to store it completely uncharged.
- c. Batteries that have been in storage for more than 3 months should be recharged for 2-3 hours at 0.2C~0.3C.
- d. Batteries should be stored in a dry, clean, ventilated, non-corrosive gas environment, away from sources of ignition, to avoid exposure to the sun.
- e. Do not store or put in high temperatures over 60°C for a long period of time, otherwise, it will cause function deterioration and life span reduction.

11. Warning

To prevent possible battery leakage, heat generation, and explosion, please observe the following warning:

Warning!

- a. It is strictly forbidden to immerse the battery in seawater or water. When not in use, it should be placed in a cool and dry environment;
- b. It is strictly forbidden to reverse the positive and negative poles to use the battery;
- c. It is forbidden to use metal to directly connect the positive and negative electrodes of the battery to a short circuit;
- d. It is forbidden to transport or store batteries together with metals, such as hairpins, necklaces, etc;
- e. It is forbidden to knock or throw, step on the battery, etc.;
- f. It is forbidden to directly weld the battery and pierce the battery with nails or other sharp objects.

Attention!

- a. It is forbidden to use or place the battery under high temperatures (in the hot sun or in a very hot car), otherwise, it may cause the battery to overheat, catch fire or fail to function, and shorten its life; the recommended temperature for long-term battery storage is 10–45°C;
- b. It is forbidden to throw batteries into fires or heaters to prevent fire, explosion, and environmental pollution. Scrapped batteries should be returned to the supplier or battery recycling point for disposal;
- c. Do not use it in places with strong static electricity and strong magnetic fields, otherwise it will easily damage the battery safety protection device and bring unsafe hidden dangers;
- d. If the battery leaks and the electrolyte enters the eyes, do not rub it. Immediately rinse the eyes with clean water and send them to the hospital for treatment, otherwise, the eyes will be hurt. If the battery emits an odor, heats up, discolors, deforms, or has any abnormality during use, storage, or charging, immediately remove the battery from the device or charger and stop using it;
- e. It is forbidden to insert the positive and negative poles of the battery directly into the power socket, and a special charger for lithium-ion batteries must be used;
- f. Check the battery voltage and connectors before installation, and use it only after everything is normal;
- g. The battery is stored in half power. If the battery has not been used for three months, it needs to be recharged once;
- h. If the electrode is dirty, it should be wiped with a dry cloth before use. Otherwise, it may cause poor contact and function failure;

Need additional information?

Just Contact BASEN!



BASEN  GREEN

**BASENGREEN
YOUR RELIABLE POWER**



Fax: (+86)0755-84737145



Tex: (+86)130 0887 9993



Email: info@Basengroup.com



Website: www.basenpower.com



Shenzhen Basen Technology Co., Ltd.



Add: Room 303, Building 3, 1980 Culture and Technology Industrial Park,
Donghuan Road, Longhua District, Shenzhen